

The International Journal of Robotics Research

<http://ijr.sagepub.com>

An Experimental Robot Load Identification Method for Industrial Application

Jan Swevers, Walter Verdonck, B. Naumer, S. Pieters and S. Biber

The International Journal of Robotics Research 2002; 21; 701

DOI: 10.1177/027836402761412449

The online version of this article can be found at:
<http://ijr.sagepub.com/cgi/content/abstract/21/8/701>

Published by:

 SAGE Publications

<http://www.sagepublications.com>

On behalf of:



Multimedia Archives

Additional services and information for *The International Journal of Robotics Research* can be found at:

Email Alerts: <http://ijr.sagepub.com/cgi/alerts>

Subscriptions: <http://ijr.sagepub.com/subscriptions>

Reprints: <http://www.sagepub.com/journalsReprints.nav>

Permissions: <http://www.sagepub.com/journalsPermissions.nav>

J. Swevers
W. Verdonck

Katholieke Universiteit Leuven
Division Production Engineering
Machine Design and Automation (PMA)
Celestijnenlaan 300B
B-3001 Heverlee, Belgium
jan.swevers@mech.kuleuven.ac.be

B. Naumer
S. Pieters
E. Biber

AMATEC Robotics GmbH
Landsberger Strasse 63a
D-82110 Germering
Germany

An Experimental Robot Load Identification Method for Industrial Application

Abstract

In this paper, we discuss a new experimental robot load identification method that is used in industry. The method is based on periodic robot excitation and the maximum likelihood estimation of the parameters, techniques adopted from Swevers et al. (1997 IEEE Transactions on Robotics and Automation 13(5):730–740). This method provides: (1) accurate estimates of the robot load inertial parameters; and (2) accurate actuator torque predictions. These are both essential for the acceptance of the results in an industrial environment. The key element to the success of this method is the comprehensiveness of the applied model, which includes, besides the dynamics resulting from the robot load and motor inertia, the coupling between the actuator torques, the mechanical losses in the motors and the efficiency of the transmissions. Accurate estimates of the robot link and motor inertial parameters, which can be considered identical for all robots of the same type, are obtained from separate experiments (see Swevers et al.), and used as a priori knowledge for the robot load identification. We present experimental results on a KUKA industrial robot equipped with a calibrated test load.

KEY WORDS—robot load identification, robot dynamics, optimal excitation, parameter estimation, industrial application

1. Introduction

The ever-increasing market demands push manufacturers to use their robots at the limits of performance, and often beyond these limits. Approximately 50% of the robots are statically or dynamically overloaded.¹ This occurs especially in spot-welding applications and handling tasks. The overloading often causes premature failure of the robot. The reason for this overloading is that the path planning for these robots is often based on a dynamic robot model that includes inaccurate estimates of the inertial parameters of the load. Tool manufacturers often cannot provide these estimates at all or at least not with sufficient accuracy.

Reducing the cycle time by optimizing the robot trajectory is an important issue. This optimization has to be based on a model of the robot dynamics, taking into account accurate estimates of the inertial parameters of the payload it is carrying (e.g., a spot-welding tool). The most important aspect of these models is their ability to accurately predict the required actuator torques based on the desired robot motion.

In general, there are two identification approaches to estimate the inertial parameters of the load. Atkeson, An and Hollerbach (1986) and Kozlowski (1998) have measured the inertial parameters directly using a wrist-mounted force-torque sensor. This approach is however not generally applicable, since most industrial robots are not equipped with these sensors. The second approach considers the robot load identification as a regular dynamic robot identification

problem since the load is rigidly fixed to the robot wrist, i.e., it can be considered as part of the last robot link. Several experimental dynamic robot identification methods exist (Hölzl 1994; Olsen and Bekley 1986; Swevers et al. 1997; Armstrong 1989; Gautier 1986; Kozłowski and Dutkiewicz 1996; Gautier and Khalil 1995). Murotsu, Senda and Ozaki (1994) have discussed robot load identification that is only applicable to space robotics. The inertial parameters are estimated from free space base velocity and acceleration measurements only.

Experimental robot identification techniques are a time and effort efficient way to obtain accurate estimates of the inertial parameters of the robot load. They estimate the parameters of dynamic robot models based on motion and actuator torque data measured during “well-designed” identification experiments, i.e., robot motions along optimized trajectories. The actuator torque data are obtained through actuator current measurements, i.e., no additional sensors are required.

In this paper we discuss an experimental robot load identification approach that borrows its experiment design and maximum likelihood parameter estimation approach from Swevers et al. (1997). This load identification approach is already recognized by industry as an effective means of robot load identification that is frequently used (Hirzinger et al. 1999). For it to have accomplished this result, the method has to satisfy the following two conditions: (1) provide a model that allows accurate prediction of the actuator torques, and (2) provide accurate estimates of the inertial parameters of the load. It will be shown that the first objective is more easy to satisfy than the second, i.e., a model which provides acceptable actuator torque predictions does not necessarily provide accurate parameter estimates. This last issue is important because the obtained model will only be accepted in an industrial environment if the values of the estimated parameters correspond to expected values of the inertial parameters.²

The key element to obtain sufficiently accurate parameter estimates is the comprehensiveness of the applied dynamic model. This model is a set of differential equations describing the relationship between the robot motion and the actuator torques. The complexity of the resulting model depends on which dynamic effects and losses are considered or neglected. For example, in classical robot identification, where the main goal is to obtain a model which allows an accurate prediction of the actuator torques, it is common practice to consider only the link motions, i.e., to neglect the dynamic effects resulting from the differences in velocity and acceleration of the rotors and their corresponding links. In this paper, we show that, in order to obtain sufficiently accurate parameter estimates, these and other dynamic effects, such as coupling between the actuator torques and losses in the motors and the transmissions, have to be considered.

The outline of the paper is as follows. In Section 2 we describe the model used for robot load identification, and we discuss how the above-mentioned dynamic effects related to the motors and transmissions are taken into account for the considered test case: a KUKA KR150 industrial robot with a calibrated load. In Section 3 we summarize the experiment design and parameter estimation approach, which are based on Swevers et al. (1997), and we discuss how these approaches are applied to the test case considered in this paper. In Section 4 we describe the test case, and we discuss and evaluate the experimental results.

2. Generation of a Dynamic Robot Model for Load Identification

The dynamic model of an n degree of freedom (DOF) robot manipulator, derived according to the Newton–Euler formalism (Craig 1989; Spong and Vidyasagar 1989), is a dynamic relation between the gear torques $\boldsymbol{\tau}_G$, i.e., the torques which drive the links, the motion of the links, i.e., the joint positions \boldsymbol{q}_G , velocities $\dot{\boldsymbol{q}}_G$, and accelerations $\ddot{\boldsymbol{q}}_G$, and the parameters of the inertia tensors of the different links, represented by vector \boldsymbol{p} . Since the robot load is connected to the last robot link (link n), the load is considered as part of this link. It is assumed that the mass and inertia tensor of link n are negligible compared to those of the load. Typically, for a KUKA robot used for spot-welding operations, the mass of link $n = 6$ itself is 3 to 10 kg, compared to the mass of the load it can carry, i.e., 100 to 350 kg. In general, the mass of the last link itself is smaller than the accuracy that can be obtained, which corresponds to a maximum relative error of 5%.

The resulting nonlinear dynamic equations (Craig 1989, Spong and Vidyasagar 1989) can be summarized as follows

$$\boldsymbol{\tau}_G = \boldsymbol{f}(\boldsymbol{q}_G, \dot{\boldsymbol{q}}_G, \ddot{\boldsymbol{q}}_G, \boldsymbol{p}, \boldsymbol{\kappa}), \quad (1)$$

with the set of inertial parameters

$$\boldsymbol{p} = [\boldsymbol{p}_1, \dots, \boldsymbol{p}_n]^T \quad (2)$$

$$\boldsymbol{p}_i = [m_i, c_{x_i}, c_{y_i}, c_{z_i}, J_{xx_i}, J_{yy_i}, J_{zz_i}, J_{xy_i}, J_{xz_i}, J_{yz_i}]^T, \quad (3)$$

for $i = 1, \dots, n$. Here m_i is the mass of link i , $c_i = [c_{x_i}, c_{y_i}, c_{z_i}]^T$ is the center of gravity of link i , \boldsymbol{J}_i is the inertia tensor of link i related to its center of gravity:

$$\boldsymbol{J}_i = \begin{bmatrix} J_{xx_i} & J_{xy_i} & J_{xz_i} \\ J_{xy_i} & J_{yy_i} & J_{yz_i} \\ J_{xz_i} & J_{yz_i} & J_{zz_i} \end{bmatrix}.$$

Vector $\boldsymbol{\kappa}$ represents the (known) kinematic parameters (distances between the joints, orientations of the joints' axes) that are fundamental to express the coupling between the links.

This model does not yet consider any losses in the motors and the transmissions, nor coupling between the actuator

2. In fact, this experience was the main motivation for AMATEC Robotics GmbH to start with the development of the presented identification method.

torques. These effects are described in the following paragraphs. The total model is described in the final paragraph of this section, which also discusses the identifiability of the model parameters.

The variables that appear in these and the following dynamic equations are all related to the link side; for example, all angles and torques are transformed to the link side by respectively dividing and multiplying them with the appropriate transmission ratio.

2.1. Relation Between Motor Current and Motor Torque

The KUKA KR150 uses permanent magnet synchronous motors. The relation between the torque and current of these motors has been identified experimentally, yielding a third-order polynomial model:

$$\begin{aligned}\tau_{M_i} &= \mu_i \text{sign}(I_i)(c_0^i + c_1^i |I_i| + c_2^i I_i^2 + c_3^i |I_i|^3) \\ &= h_i(I_i, \mu_i, \boldsymbol{\gamma}_i).\end{aligned}\quad (4)$$

I_i represents the actuator current of link i . μ_i is the transmission ratio of joint i . $\boldsymbol{\gamma}_i$ represents the vector which contains the parameters of the third-order polynomial. This model is more accurate than the often used linear relation between motor current and torque, especially at large motor currents. Figure 1 shows the difference between both models for the motors of the third and fifth axes of the KUKA KR150. All wrist axis motors are identical. The dependency of the motor torque on the motor velocity, the acceleration, and the temperature is neglected.

2.2. Actuator Dynamics

A considerable part of the actuator torque is consumed by actuator friction and by accelerating and decelerating its rotor inertia. Therefore, accurate dynamic robot models have to include these effects. A simple and good actuator friction model includes viscous and Coulomb friction

$$\tau_{F_i} = R_{v_i} \dot{q}_{M_i} + R_{c_i} \text{sign}(\dot{q}_{M_i}) \quad (5)$$

where \dot{q}_{M_i} is the angular velocity of the actuator of joint i , τ_{F_i} is the total friction torque consumed in the actuator of joint i , and R_{v_i} and R_{c_i} are the corresponding viscous and Coulomb friction parameters. A more complex friction model is obtained by using different coefficients depending on the direction of the motion (Hölzl 1994), or by including Stribeck, pre-sliding hysteresis behavior, etc. (Swevers et al. 2000). These effects are not considered here since their inclusion in the robot model has shown no improvement of the accuracy of the estimated load parameter.

The torque resulting from the accelerating and decelerating rotor inertia of the actuator of joint i equals:

$$\tau_{I_i} = J_{M_i} \ddot{q}_{M_i}. \quad (6)$$

The net actuator torque at the input of the transmission equals:

$$\begin{aligned}\tau_{T_i} &= \tau_{M_i} - \tau_{I_i} - \tau_{F_i} \\ &= \tau_{M_i} - J_{M_i} \ddot{q}_{M_i} - R_{v_i} \dot{q}_{M_i} - R_{c_i} \text{sign}(\dot{q}_{M_i}).\end{aligned}\quad (7)$$

2.3. Efficiency of the Transmission

The mechanical transmission between the actuator and link is a complex system, with many parts moving at different angular velocities. This makes it difficult to model the losses in the transmission by means of a friction model. A more appropriate approach is to consider the efficiency of the transmission, which depends in a nonlinear way on the actuator velocity \dot{q}_{M_i} and remaining torque τ_{T_i} and is modeled using only one parameter per joint R_{z_i} :

$$\begin{aligned}\tau'_{G_i} &= g(\tau_{T_i}, \dot{q}_{M_i}, R_{z_i}) \\ &= \begin{cases} \tau_{T_i} \times R_{z_i} & \text{if } \tau_{T_i} \dot{q}_{M_i} > 0 \\ \tau_{T_i} / R_{z_i} & \text{if } \tau_{T_i} \dot{q}_{M_i} < 0 \end{cases}.\end{aligned}\quad (8)$$

τ_{T_i} and τ'_{G_i} are the torques at the input and output of the transmission of joint i , respectively.

2.4. Coupling between the Actuator Torques

The robot considered in this paper is a KUKA KR150, which is a six DOF robot ($n = 6$). Due to its design, the three axes of the wrist of this robot, and of all KUKA robots with six DOF, are coupled in the sense that the motion of each wrist link is determined by more than one wrist actuator. The following linear relation describes this coupling

$$\mathbf{q}_G = \mathbf{V} \mathbf{q}_M, \quad (9)$$

$$\boldsymbol{\tau}'_G = \mathbf{V}^T \boldsymbol{\tau}_G, \quad (10)$$

where \mathbf{q}_G , $\boldsymbol{\tau}_G$, \mathbf{q}_M , and $\boldsymbol{\tau}'_G$ are the six-vectors containing the joint angles, the joint torques, the motor angles, and the net actuator torques (eq. (10)), respectively.

For the KUKA KR150

$$\mathbf{V} = \begin{bmatrix} 1 & 0 & 0 & 0 & 0 & 0 \\ 0 & 1 & 0 & 0 & 0 & 0 \\ 0 & 0 & 1 & 0 & 0 & 0 \\ 0 & 0 & 0 & 1 & 0 & 0 \\ 0 & 0 & 0 & V_2 & 1 & 0 \\ 0 & 0 & 0 & V_0 & V_1 & 1 \end{bmatrix} \quad (11)$$

with $V_0 = 0.0138$, $V_1 = -0.0140$, and $V_2 = 0.0093$.

REMARK 1. This modeling approach considers the kinematic coupling \mathbf{V} after the transmission efficiency. This choice is arbitrary and their order can be reversed without introducing significant differences due to the rather small coupling elements V_0 , V_1 , and V_2 .

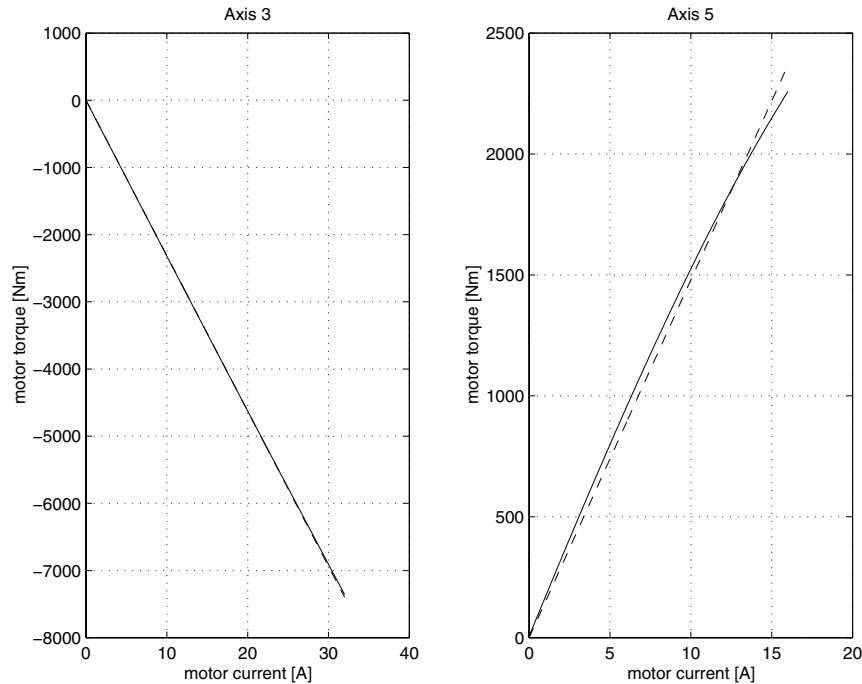

Fig. 1. Third-order (full line) and first-order (dashed line) polynomial models relating current and torque of the permanent magnet synchronous motors of the KUKA KR150 robot. Left figure, motor of axis 3; right figure, motor of axis 5.

2.5. Total Robot Model

Combining eqs. (1), (4), (7), (8), (9), and (10) yields the following dynamic robot model

$$\mathbf{h}(\mathbf{I}, \boldsymbol{\mu}, \boldsymbol{\gamma}) = \mathbf{F}(\mathbf{q}_M, \dot{\mathbf{q}}_M, \ddot{\mathbf{q}}_M, \mathbf{V}, \boldsymbol{\kappa}, \boldsymbol{\theta}), \quad (12)$$

with

$$\begin{aligned} \mathbf{h}(\mathbf{I}, \boldsymbol{\mu}, \boldsymbol{\gamma}) &= [h_1(I_1, \mu_1, \gamma_1) \quad \dots \quad h_n(I_n, \mu_n, \gamma_n)]^T \\ &= \boldsymbol{\tau}_M. \end{aligned} \quad (13)$$

$\boldsymbol{\tau}_M$ is the vector containing all actuator torques τ_{M_i} . $\mathbf{F}(\cdot)$ is the vector function which summarizes eqs. (1)–(11). It relates the measured variables, i.e., the motor currents and motor angles, velocities and accelerations, to the model parameters:

$$\boldsymbol{\theta} = [p \quad \mathbf{R}_v \quad \mathbf{R}_c \quad \mathbf{J}_M \quad \mathbf{R}_z]^T. \quad (14)$$

Here, \mathbf{R}_v , \mathbf{R}_c , \mathbf{J}_M , and \mathbf{R}_z are the n -vectors containing for all axes the motor viscous and Coulomb friction coefficients, the motor inertia, and the efficiency parameters of the transmission, respectively. $\boldsymbol{\theta}$ contains $14 \times n$ parameters. If only $m \leq n$ axes are actuated during the excitation experiment, the number of parameters appearing in the model reduces to $14 \times m$. The robot load identification method discussed below considers experiments where only the third axis and the three wrist axes are actuated, and in addition does not consider all

parameters as unknown; the values of some of the parameters are known from other experiments and considered as a priori knowledge in the robot load identification.

The motor angles are measured by means of the encoders mounted on the motor shafts. The motor velocities and accelerations are not measured directly, but are derived from the angle measurements analytically as described in Swevers et al. (1997).

REMARK 2. The discussed models consider actuator friction only, i.e., neglect friction in the joints. This is an approximation which we found to be sufficiently accurate. The difference between the joint and actuator motion, and therefore friction if it is modeled by means of Coulomb and viscous friction, is introduced by the coupling matrix. Transformation of the actuator friction, by means of the coupling matrix, introduces additional coupling friction torques that are less than 1% of these torques. Therefore, neglecting joint friction torques introduces errors that are smaller than the systematic errors due to restricting the friction model to Coulomb and viscous friction only.

REMARK 3. Due to motion constraints (e.g., each robot rotation axis has only one DOF) and the measurement constraints (only the joint motion and the actuator currents (torques) are measured) not all ten inertial parameters of each link are identifiable; some are identifiable in combinations and other parameters do not appear in the dynamical equations. The

construction of a base set of independent inertial parameters, i.e., a complete and minimal parametrization, can be performed a priori, from the kinematic structure of the robot. Various methods have been proposed: numerical methods (Izaguirre et al. 1992; Gautier 1990; Sheu and Walker 1989), and symbolic methods (Mayeda, Yoshida and Osuka 1990; Mayeda and Maruyama 1991; Gautier and Khalil 1990; Fisette, Raucant and Samin 1993; Raucant and Samin 1994; Khalil and Bennis 1994; Huo 1995). It is assumed that this parameter reduction has been performed. The resulting base set of inertial parameters for the considered robot load identification problem is further discussed in Section 4.

The rotor inertia of all actuators and the inertial parameters of all robot links except link 6, since this link is considered as part of the load, are constant and can be considered identical for all robots of the same type. Those that influence the robot dynamics can be determined a priori using a series of identification experiments, and can be considered as known for the robot load identification, reducing the number of unknown parameters in θ , and the uncertainty on the estimates of these parameters (Schoukens and Pintelon 1991). The Coulomb and viscous friction parameters, and the parameters that model the efficiency of the transmissions are not constant and therefore are considered to be unknown. They are robot- and temperature-dependent.

3. Experiment Design and Parameter Estimation Issues

In this section we discuss experiment design and parameter estimation, which are based on Swevers et al. (1997), in view of robot load identification.

3.1. Experiment Design

The excitation trajectory for each joint is a finite sum of harmonic sine and cosine functions, i.e., a finite Fourier series

$$q_i(k) = \sum_{l=1}^{N_i} (a_l^i \sin(\omega_f l k T_s) + b_l^i \cos(\omega_f l k T_s)) + q_{i0} \quad (15)$$

$$\dot{q}_i(k) = \sum_{l=1}^{N_i} (a_l^i \omega_f l \cos(\omega_f l k T_s) - b_l^i \omega_f l \sin(\omega_f l k T_s)) \quad (16)$$

$$\ddot{q}_i(k) = \sum_{l=1}^{N_i} (-a_l^i \omega_f^2 l^2 \sin(\omega_f l k T_s) - b_l^i \omega_f^2 l^2 \cos(\omega_f l k T_s)) \quad (17)$$

where ω_f is the fundamental pulsation of the Fourier series. k indicates the discrete time and T_s is the sampling time. This Fourier series specifies a periodic function with period $T_f =$

$2\pi/\omega_f$. The fundamental pulsation is common for all joints in order to preserve the periodicity of the overall robot excitation, which:

- is advantageous because it allows time-domain data averaging, which yields data reduction and improves the signal to noise ratio of the experimental data—this is especially important for the motor current measurements since they are very noisy;
- allows estimation of the characteristics of the measurement noise (Swevers et al. 1997)—this information is valuable in the case of maximum likelihood parameter estimation;
- allows an analytic calculation of the joint velocities and accelerations from the measured response (Swevers et al. 1997).

Each Fourier series contains $2 \times N_i + 1$ parameters, which constitute the DOF for the excitation trajectory: a_l^i , and b_l^i , for $l = 1$ to N_i , which are the amplitudes of the cosine and sine functions, and q_{i0} which is the offset on the position trajectory. These can be fixed, for example, through optimization, as done in Swevers et al. (1997), or by means of trial and error.

The unique estimation of all inertial parameters of the robot load does not require that all robot axes are activated during the identification experiment, as shown in Section 4 where we discuss robot load identification based on an experiment which only excites axis 3 and the three wrist axes.

3.2. Parameter Estimation

The robot load identification method discussed in this paper is based on the maximum likelihood estimation method presented in Swevers et al. (1997). This method yields the parameter vector θ which maximizes the likelihood of the measurement. In its general formulation, this method assumes that the measured joint angles and actuator torques are both corrupted by independent zero-mean Gaussian noise. The minimization of such a likelihood function is a nonlinear least-squares minimization problem. Swevers et al. (1997) also discuss the case when the joint angle measurements are free of noise. This simplifies the minimization problem to the *Markov estimate*, i.e., the *weighted linear least-squares estimate*, if the model is linear in the parameters, which is the case if barycentric parameters are used (Maes, Samin and Willems 1989; Wittenburg 1977). The robot load identification presented in this paper adopts the same assumption, i.e., noise-free joint angle measurements. However, this does not simplify the parameter estimation to a **linear** least-squares problem since the robot model (13) is not linear in the parameters.

Based on this discussion, the parameter estimation can be formulated as the following nonlinear least-squares problem

$$\theta_{ML} = \arg \min_{\theta} \sum_{k=1}^N \sum_{i \in \mathcal{D}} \frac{(\tau_{M_i}(k) - \mathbf{F}_i(\mathbf{q}_M(k), \dot{\mathbf{q}}_M(k), \ddot{\mathbf{q}}_M(k), \mathbf{V}, \theta_1, \theta_2))^2}{\sigma_{\tau_i}^2} \quad (18)$$

where \mathbf{F}_i is the i th element of \mathbf{F} (12). σ_{τ_i} is the standard deviation of the noise on τ_{M_i} . \mathcal{D} indicates the set of axes which are actuated during the identification experiment. The vectors θ_1 and θ_2 represent the subsets of model parameters which are respectively considered as unknown and known for the robot load identification.

This optimization problem can be solved using the Levenberg–Marquardt iterative search method (Fletcher 1991). The application of these methods requires:

- an initial estimate of the unknown model parameters; and
- the calculation of the Jacobian of $\mathbf{F}_i, i \in \mathcal{D}$, with respect to the unknown model parameters θ_1 .

The unknown parameters for the robot load identification problem are the ten inertial parameters of the load, the Coulomb and viscous friction parameters, and the parameters which model the efficiency of the transmissions. All other dynamic parameters appearing in the model are independent of the robot load and are considered a priori information for the estimation.

An initial guess of the inertial parameters of the robot load is obtained by first considering a robot model which is linear in its parameters. This initial estimation is performed using the same set of experimental data as the following iterative search, and corresponds to a (weighted) linear least-squares problem (Swevers et al. 1997). The considered unknown parameters are the barycentric parameters of the robot with load (Maes, Samin and Willems 1989; Wittenburg 1977), and the Coulomb and viscous motor friction parameters. This model does not consider the efficiency of the transmission, and uses fixed values for the rotor inertia J_{M_i} . An initial guess of the ten inertial parameters of the load is then obtained from these barycentric parameter estimates and the a priori known inertial parameters of the other links, by solving a set of equations.

The Jacobian of $\mathbf{F}_i, i \in \mathcal{D}$, with respect to the unknown parameters, is calculated recursively following the Newton–Euler formalism used for the derivation of the robot model (1). The rank of this Jacobian determines whether all unknown parameters θ_1 are identifiable. In Section 4 we discuss this matter in more detail.

4. Experimental Validation

In this section we discuss the implementation and experimental validation of the above-mentioned robot load identification

procedure on a KUKA KR150 with a calibrated load. In Section 4.1 we describe the considered test case, in Section 4.2 we discuss the experiment design and parameter estimation, and in Section 4.3 we summarize the experimental results.

4.1. Description of the Test Case

The test case consists of a KUKA KR150 industrial robot equipped with a calibrated test load. This robot, which is used in industry mainly for spot-welding applications, has six rotary axes. Figure 2 shows this robot with a spot-welding tool.

To enable the experimental validation of the developed load identification procedure a calibrated test tool has been designed. This test load is reconfigurable, allowing large variations of the mass, the position of the center of gravity, and of the moments of inertia. It consists of a basic body, two bent arms, 20 disks and two connecting flanges to attach the disks. The basic body can be mounted in different positions to the robot end effector. The basic body itself offers four possible ways to attach either the two arms or an arbitrary number of disks. These disks can also be attached to the end of the arms, resulting in large moments of inertia. Figure 3 shows the particular configuration of the test load as it is used in the experiments described below. The ten inertial parameters of this configuration are shown in the second column of Table 2. These parameter values result from the computer-aided design (CAD) model of the test load and from weighting different parts of the load.

4.2. Practical Implementation of the Experiment Design and Parameter Estimation for the KUKA KR150

All unknown model parameters θ_1 can be estimated uniquely if the Jacobian of $\mathbf{F}_i, i \in \mathcal{D}$, with respect to these parameters is of full rank. If this is the case, its condition number and the determinant of the inverse of this matrix squared indicate the expected accuracy of the estimated parameters (Swevers et al. 1997; Schoukens and Pintelon 1991).

It is not possible to estimate the ten inertial parameters of all robot links uniquely in one experiment. However, since the inertial parameters of all robot links are constant, except for link 6 since it is considered as part of the load, they can be determined a priori using a series of identification experiments. The values of these parameters and of the rotor inertia can be considered identical for all robots of the same type. For the robot load identification problem, these parameters are considered as known, i.e., part of θ_2 . The inertial parameters of link 6 vary with the load and are part of θ_1 . The Coulomb and viscous friction parameters, and the parameters which model the efficiency of the transmissions are not constant and therefore are considered unknown. They are robot-dependent and temperature-dependent.

An analysis of the rank of the above-mentioned Jacobian shows that it is necessary to move axes 3 to 6 to allow the



Fig. 2. KUKA KR150 industrial robot with spot-welding tool.

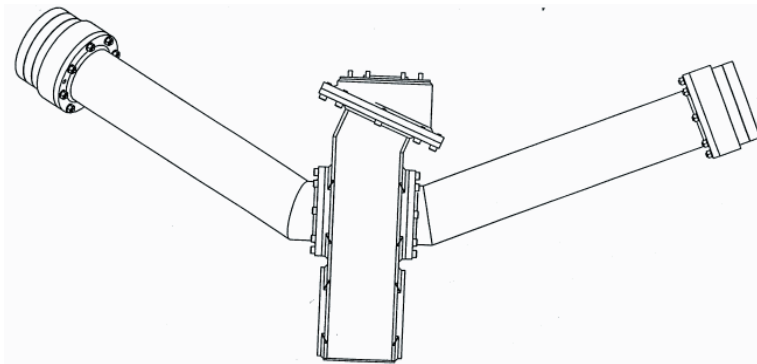

Fig. 3. Schematic representation of the calibrated test load.

unique identification of all 22 unknown parameters. If only the wrist axes are moved, the number of unknown parameters reduces to 19. However, it is then not possible to identify the mass of the load; the rank of the Jacobian is 18.

The trajectories for axes 3 to 6 have not been optimized. Instead, the parameters of the trajectories for the wrist axes have been chosen such that the whole working envelope of the robot wrist is covered, taking into account constraints on joint velocities and accelerations. A small movement for axis 3 is sufficient since this motion is only required for the identification of the mass of the load. This approach is not optimal but avoids a complex and time-consuming optimization. The parameters of these trajectories have been selected by means of trial and error, which is feasible since only a limited number of axes are involved. Figure 4 shows one of the sets of tra-

jectories that has been used for the robot load identification. The period of the excitation is 36.96 s, yielding a fundamental pulsation of 0.0271 Hz. The sampling period is equal to 24 ms, yielding 1540 samples per period.

Table 1 summarizes the non-zero Fourier coefficients (15) of the trajectories shown in Figure 4.

4.3. Implementation of the Robot Load Identification

A set of excitation trajectories for axes 3, 4, 5, and 6, as that described in Section 4.2 (Figure 4), is applied periodically. Data are collected during ten periods, after the transient response of the robot has died out. The joint angles are measured by means of an encoder mounted on the motor shaft, and the actuator torques are measured indirectly by means of the motor current, using eq. (4).

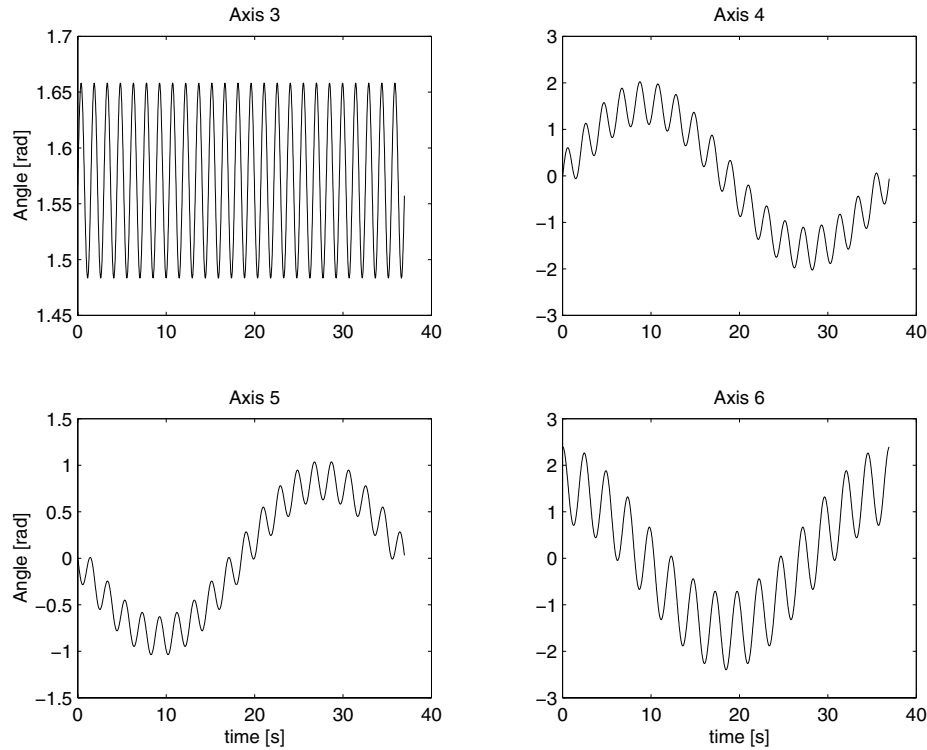

Fig. 4. One of the sets of excitation trajectories for axes 3, 4, 5, and 6.

Table 1. Non-zero Fourier Coefficients a_l^i and b_l^i (15) of the Excitation Trajectories Shown in Figure 4

Axis 3	Axis 4	Axis 5	Axis 6
$q_{30} = 1.57$			
	$a_1^4 = 1.57$	$a_1^5 = -8.38 \times 10^{-1}$	$a_1^6 = 0$
	$b_1^4 = 0$	$b_1^5 = 1.78 \times 10^{-3}$	$b_1^6 = 1.57$
$a_{25}^3 = 8.72 \times 10^{-2}$	$a_{18}^4 = 4.60 \times 10^{-1}$	$a_{19}^5 = -2.10 \times 10^{-1}$	$a_{15}^6 = 2.56 \times 10^{-2}$
$b_{25}^3 = -4.62 \times 10^{-3}$	$b_{18}^4 = -1.76 \times 10^{-2}$	$b_{19}^5 = 8.52 \times 10^{-3}$	$b_{15}^6 = 1.57$

The data sequences are then averaged over ten periods in order to improve the signal-to-noise ratio of the measurements. This is especially important for the motor current/torque measurements.

Figure 5 shows the averaged motor torque measurements for the excitation trajectory shown in Figure 4.

The variance of the noise on the averaged actuator torque measurements is estimated by calculating the sample variance, and dividing it by 10:

$$\hat{\sigma}_{\tau_{M_i}}^2 = \frac{1}{10} \frac{1}{(10N - 1)} \sum_{k=1}^N \sum_{j=1}^{10} (\tau_{M_{ij}}(k) - \bar{\tau}_{M_i}(k))^2.$$

N is equal to the number of samples per period, i.e., 1540. Subscript j indicates the excitation period ($j = 1, 2, \dots, 10$). $\bar{\tau}_{M_i}(k)$ represents the averaged motor torque measurement. Note that the estimation of the variance according to the

above-mentioned equations and the improvement of the signal-to-noise ratio through data averaging are only possible because of the periodicity of the excitation.

The joint angular velocities $\dot{q}_{M_i}(k)$ and accelerations $\ddot{q}_{M_i}(k)$ are calculated using eqs. (16)–(17). For this purpose, the trajectory parameters q_{i0} , a_l^i , and b_l^i (eq. (15)) are re-estimated using the discrete Fourier transform of the averaged encoder measurements. This also provides noise-free estimates of the joint angle measurements, which are denoted by $q_{M_i}(k)$, by applying these re-estimated trajectory parameters in eq. (15). The re-estimation of the trajectory parameters allows us to account for tracking errors that could have occurred during the execution of the experiments due to the limitations of the robot controller. More harmonics can be considered in this estimation depending on the frequency contents of the tracking error.

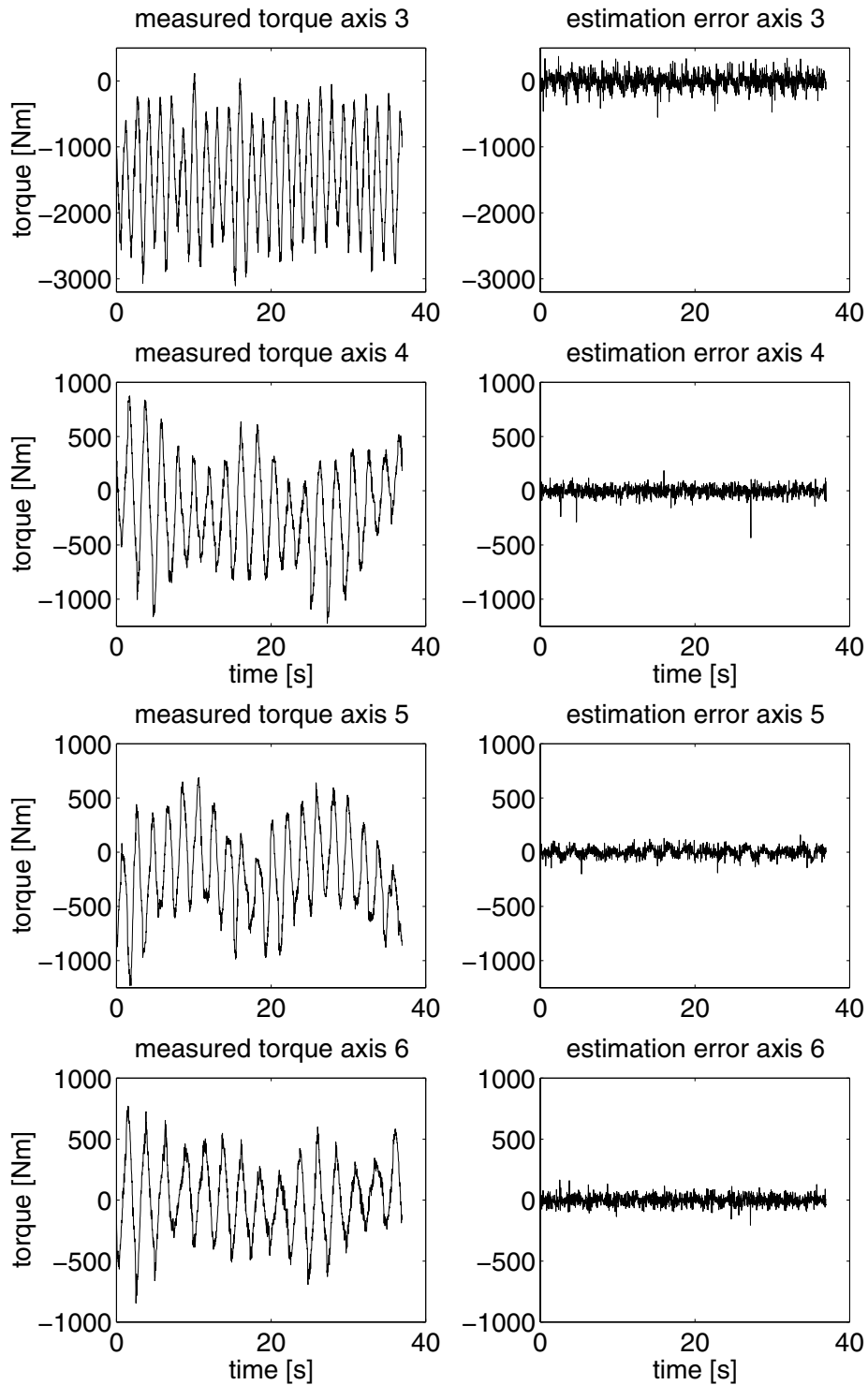

Fig. 5. Averaged motor torque measurements (left) and torque estimation errors (right).

This frequency-domain approach towards the differentiation of the encoder measurements is simple, efficient, and accurate: no leakage errors are introduced because of the periodicity of the signals, and a noise filtering is provided by omitting non-excited frequency lines from the Fourier transform (Swevers et al. 1997).

The unknown model parameters θ_1 are estimated based on the models (12)–(13), and using the noise-free estimates of joint angles, velocities and accelerations, $q_{M_i}(k)$, $\dot{q}_{M_i}(k)$, and $\ddot{q}_{M_i}(k)$ respectively, and averaged actuator torque measurements $\bar{\tau}_{M_i}(k)$. This estimation corresponds to the nonlinear least-squares optimization problem (18), that considers noise on the actuator data measurements only. This optimization is solved using iterative search methods starting from an initial guess of the unknown parameters, as described in Section 3.2.

4.4. Validation of the Experimental Results

Tables 2 and 3 give an overview of the obtained experimental results. The second column of Table 2 shows the exact values of the inertial parameters of the calibrated load. Columns 3 to 5 compare the results obtained using three alternative approaches:

- **Approach 1:** The model used in this approach is based on the barycentric parameters of links 3 to 6 (Maes, Samin and Willems 1989), and includes the motor friction coefficients (viscous and Coulomb) and the rotor inertias as unknown. This model is linear in the parameters, which simplifies their estimation considerably. The efficiencies of the transmissions are fixed to 1. This estimation approach corresponds exactly to the robot identification approach presented in Swevers et al. (1997). The inertial parameters of the test load are derived from the estimated barycentric parameters using accurate a priori estimates of inertial parameters of the links.
- **Approach 2:** This approach uses model (12) and estimation criterion (18), i.e., it is the robot load identification approach discussed in this paper, except for the efficiencies of the transmissions, which are fixed to 1. The rotor inertias and inertial parameters of the links are fixed to a priori estimated values. The motor friction parameters are considered unknown.
- **Approach 3:** This approach corresponds to approach 2, except that the efficiencies of the transmissions are now considered as unknown.

The inertial parameters of the test load are estimated according to these three approaches using data resulting from 14 different experiments, yielding 14 sets of estimates for each approach. Columns 3 to 5 of Table 2 show the average errors with respect to the exact values (column 2) and the standard deviation of these sets of 14 estimates. Table 3 shows, for one

of the experiments, the root mean square actuator torque estimation errors resulting from the models obtained with the three different estimation approaches.

A comparison of these results shows that:

- The load parameters provided by the first approach are not accurate enough because: (1) the efficiencies of the transmissions cannot be included in the linear approach; (2) some parameters are only identifiable in combination with others; and (3) the used identification trajectories only guarantee a sufficient excitation for the load parameter identification, not for all other parameters of the robot. The model, however, yields accurate actuator torque predictions. This can be understood from the fact that the model contains a large number of parameters. These parameters are the DOF of the parameter estimation, which is a least-squares minimization of the actuator torque prediction.
- Approach 3 yields the best results with respect to parameter accuracy. In addition, the actuator torque prediction accuracy of the models resulting from approaches 3 and 1 are comparable, and better than that of the models resulting from approach 2. This shows that the inclusion of the efficiency of the transmissions in the model and in parameter estimation is required.

REMARK 4.

1. Including a priori knowledge of certain parameters, e.g., rotor inertias, inertial parameters of links 3 to 5, in the parameter estimation problem reduces the uncertainty on the identified load parameters (Schoukens and Pintelon 1991). This has been verified experimentally. Estimation of all parameters in model (12)–(14) yields larger deviations on the load parameter estimates than those shown in Table 2.
2. The accuracy of the load mass estimation presented in this paper cannot always be reached. Nevertheless, experiments on a large number of industrial robots have shown that the relative error is always smaller than 5%. Consequently, it is justified to assume that the inertial parameters of the link 6 are negligible with respect to those of a typical robot load.

5. Conclusion

The presented experimental robot load identification method is based on the robot identification method described in Swevers et al. (1997); the experiment design and maximum likelihood parameter estimation approaches are adopted. The modeling approach however is different; instead of using a barycentric parameter description of the robot dynamics, the

Table 2. Overview of Experimental Results: Comparison of the Accuracy of the Inertial Parameter Estimates Obtained Using Three Different Approaches

Parameter	Exact value	Average estimation error		
		Approach 1	Approach 2	Approach 3
m (kg)	125.46	13.24 ± 1.1	0.81 ± 1.0	0.85 ± 0.9
c_x (mm)	88	1 ± 1.4	1 ± 2	1 ± 1
c_y (mm)	-32	3 ± 1.1	3 ± 1	2 ± 0.9
c_z (mm)	140	4 ± 4.8	6 ± 4	4 ± 5
I_{xx} (kg m ²)	38.21	5.96 ± 1.0	1.13 ± 0.8	0.70 ± 0.6
I_{yy} (kg m ²)	6.55	5.10 ± 0.6	1.23 ± 0.7	1.72 ± 0.7
I_{zz} (kg m ²)	37.13	4.09 ± 0.3	0.46 ± 0.6	0.39 ± 0.2
I_{xy} (kg m ²)	7.28	1.06 ± 0.4	0.66 ± 0.6	0.26 ± 0.3
I_{xz} (kg m ²)	1.49	0.23 ± 0.2	0.23 ± 0.3	0.34 ± 0.4
I_{yz} (kg m ²)	-1.23	0.12 ± 0.2	0.46 ± 0.5	0.18 ± 0.1

Table 3. Overview of Experimental Results: Comparison of the Actuator Torque Prediction Errors for the Three Different Approaches/Models

	The rms actuator torque estimation errors (one experiment)		
	Approach 1	Approach 2	Approach 3
Axis 3 (Nm)	84	111	109
Axis 4 (Nm)	48	52	42
Axis 5 (Nm)	41	48	40
Axis 6 (Nm)	38	43	39

model depends on the inertial parameters of the load. In addition, the model takes into account the dynamics resulting from the robot inertia, coupling between the actuator torques and losses in the motors and the transmissions. The rotor inertias and inertial parameters of the links are set to a priori determined values. Experimental results show that this modeling approach and the inclusion of these effects are essential to obtain sufficiently accurate parameter estimates. The obtained parameter and actuator torque prediction accuracies of the resulting dynamic model satisfy the requirements imposed by industrial users of robots. This new method is therefore recognized by industry as an effective means of robot load identification.

Acknowledgments

The authors gratefully acknowledge financial support by the Belgian Programme on Inter-University Attraction Poles initiated by the Belgian State—Prime Minister's Office—Science Policy Programme (IUAP), K. U. Leuven's Concerted Research Action GOA/99/04. The scientific responsibility is assumed by its authors.

References

- Armstrong, B. 1989. On finding exciting trajectories for identification experiments involving systems with nonlinear dynamics. *International Journal of Robotics Research* 8(6):28–48.
- Atkeson, C. G., An, C. H., and Hollerbach, J. M. 1986. Estimation of inertial parameters of manipulator loads and links. *International Journal of Robotics Research* 5(3):101–119.
- Craig, J. J. 1989. *Introduction to Robotics*. New York: Addison-Wesley.
- Fisette, P., Raucant, B., and Samin, J.-C. 1993. *Minimal dynamic characterization of tree-like multibody systems. Computer aided analysis of rigid and flexible mechanical systems*, NATO-Advanced Study Institute, vol. II, pp. 111–129.
- Fletcher, R. 1991. *Practical Methods of Optimization* 2nd edition. New York: Wiley.
- Gautier, M. 1986. Identification of robot dynamics. *Proc. IFAC Symposium on Theory of Robots*, pp. 351–356.
- Gautier, M. 1990. Numerical calculation of the base inertial parameters of robots. *Proceedings of the IEEE International Conference on Robotics and Automation*, pp. 1020–1025.

- Gautier, M., and Khalil, W. 1990. Direct calculation of minimum set of inertial parameters of serial robots. *IEEE Journal of Robotics and Automation* 6(3):368–373.
- Gautier, M., and Khalil, W. 1995. Identification of dynamic parameters of a closed loop robot. *Proceedings of the IEEE International Conference on Robotics and Automation*, pp. 3045–3050.
- Hirzinger, G., Fischer, M., Brunner, B., Koeppe, R., Otter, M., Grebenstein, M., and Schäfer, I. 1999. Advances in robotics: the DLR experience. *International Journal of Robotics Research* 18(11):1064–1087.
- Hözl, J. 1994. *Modellierung, Identifikation und Simulation der Dynamik von Industrierobotern*. Fortschritt-Berichte VDI, Reihe 8, Nr. 372. Düsseldorf: VDI-Verlag.
- Huo, W. 1995. New formulas for complete determining base parameters of robots. *Proceedings of the IEEE International Conference on Robotics and Automation*, pp. 3021–3026.
- Izagirre, A., Hashimoto, M., Paul, R., and Hayward, V. 1992. A new computational structure for real-time dynamics. *International Journal of Robotics Research* 11(4):346–361.
- Khalil, W., and Bennis, F. 1994. Comments on “direct calculation of minimum set of inertial parameters of serial robots.” *IEEE Journal of Robotics and Automation* 10(1):78–79.
- Kozlowski, K. 1998. *Modelling and Identification in Robotics*. New York: Springer Verlag.
- Kozlowski, K., and Dutkiewicz, P. 1996. Experimental identification of robot and load dynamics. In *Triennial World Congress IFAC*, pp. 397–402.
- Maes, P., Samin, J. C., and Willems, P. Y. 1989. Linearity of multibody systems with respect to barycentric parameters: dynamic and identification models obtained by symbolic generation. *Mechanics of Structures and Machines* 17(2):219–237.
- Mayeda, H., and Maruyama, M. 1991. Identification method for general open-loop kinematic chain dynamic models. *Preprints of the Second International Symposium on Experimental Robotics*, pp. 1091–1094.
- Mayeda, H., Yoshida, K., and Osuka, K. 1990. Base parameters of manipulator dynamic models. *IEEE Journal of Robotics and Automation* 6(3):312–321.
- Murotsu, Y., Senda, K., and Ozaki, M. 1994. Parameter identification of unknown object handled by free-flying space robot. *Journal of Guidance, Control, and Dynamics* 17(3):488–494.
- Olsen, H. B., and Bekley, G. A. 1986. Identification of robot dynamics. *Proceedings of the IEEE International Conference on Robotics and Automation*, pp. 1004–1010.
- Raucent, B., and Samin, J.-C. 1994. Minimal parameterization of robot dynamic models. *Mechanics of Structures and Machines* 22(3):371–396.
- Schoukens, J., and Pintelon, R. 1991. *Identification of Linear Systems, A Practical Guideline to Accurate Modeling*. Pergamon Press.
- Sheu, S.-Y., and Walker, M. 1989. Basis sets for manipulator parameters. *Proceedings of the IEEE International Conference on Robotics and Automation*, pp. 1517–1522.
- Spong, M. W., and Vidyasagar, M. 1989. *Robot Dynamics and Control*. John Wiley and Sons.
- Swevers, J., Al-Bender, F., Ganseman, C., and Prajogo, T. 2000. An integrated friction model structure with improved presliding behaviour for accurate friction compensation. *IEEE Transactions on Automatic Control* 45(4):675–686.
- Swevers, J., Ganseman, C., Tükel, D.B., De Schutter, J., and Van Brussel, H. 1997. Optimal robot excitation and identification. *IEEE Transactions on Robotics and Automation* 13(5):730–740.
- Wittenburg, J. 1977. *Dynamics of Systems or Rigid Bodies*. Stuttgart: Teubner.